

Agitator OMDR S112 - technical information

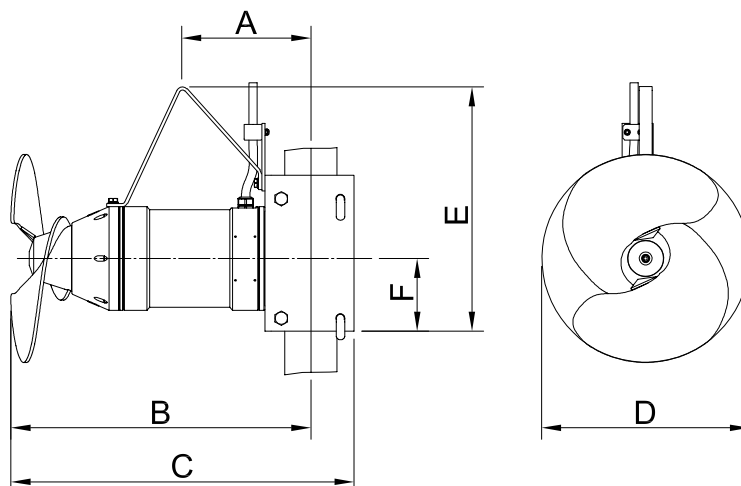

TYPE	P2 kW	Amp.	n1 min ⁻¹	n2 min ⁻¹	A mm	B mm	C mm	D mm	E mm	F mm	H kg	Q m ³ /s
OMDR S112-1,5kW-2R	1,5	5,8	750	750	250	560	645	380	470	140	66	0,23
OMDR S112-2,5kW-2R	2,5	7,1	750	750	250	560	645	440	470	140	67	0,30

Voltage : 3x400V / 50Hz / 8-pole
 Cable : 8 m H07-RNF 7x1,5mm²
 Insulation class : F, 155°
 Motor safety : IEC 34-5 IP58
 Electrical safety : 3 bimetallic sensors and leak sensor
 Start : DOL
 Motor casing : AISI 316
 Front casing : AISI 316
 Propeller : 2-bl. in AISI 316 (2R)
 Motor shaft : St. 52-3
 Output shaft : AISI 329
 Sealing, motor side : Carbon/Ceramic
 Sealing, propeller side : SiC/SiC
 Fittings : Galvanized steel or AISI 316

P2 Motor power
 Amp. Ampere input
 n1 Motor rotations
 n2 Propeller rotations
 A Length from centre of gravity to centre of mast
 B Length to centre of mast
 C Overall length
 D Propeller diameter
 E Total height
 F Height from centre of agitator to lower edge of motor bracket
 H Weight incl. trap clamp and motor bracket
 Q Capacity - in water

LJM



Lind Jensens Maskinfabrik A/S
 Kroghusvej 7, Højmark, DK-6940 Lem St.
 Tel.: +45 97 34 32 00 Fax: +45 96 74 42 98
 E-mail: industri@ljm.dk Home page: www.ljm.dk



Agitator OMDR S112 - technical information

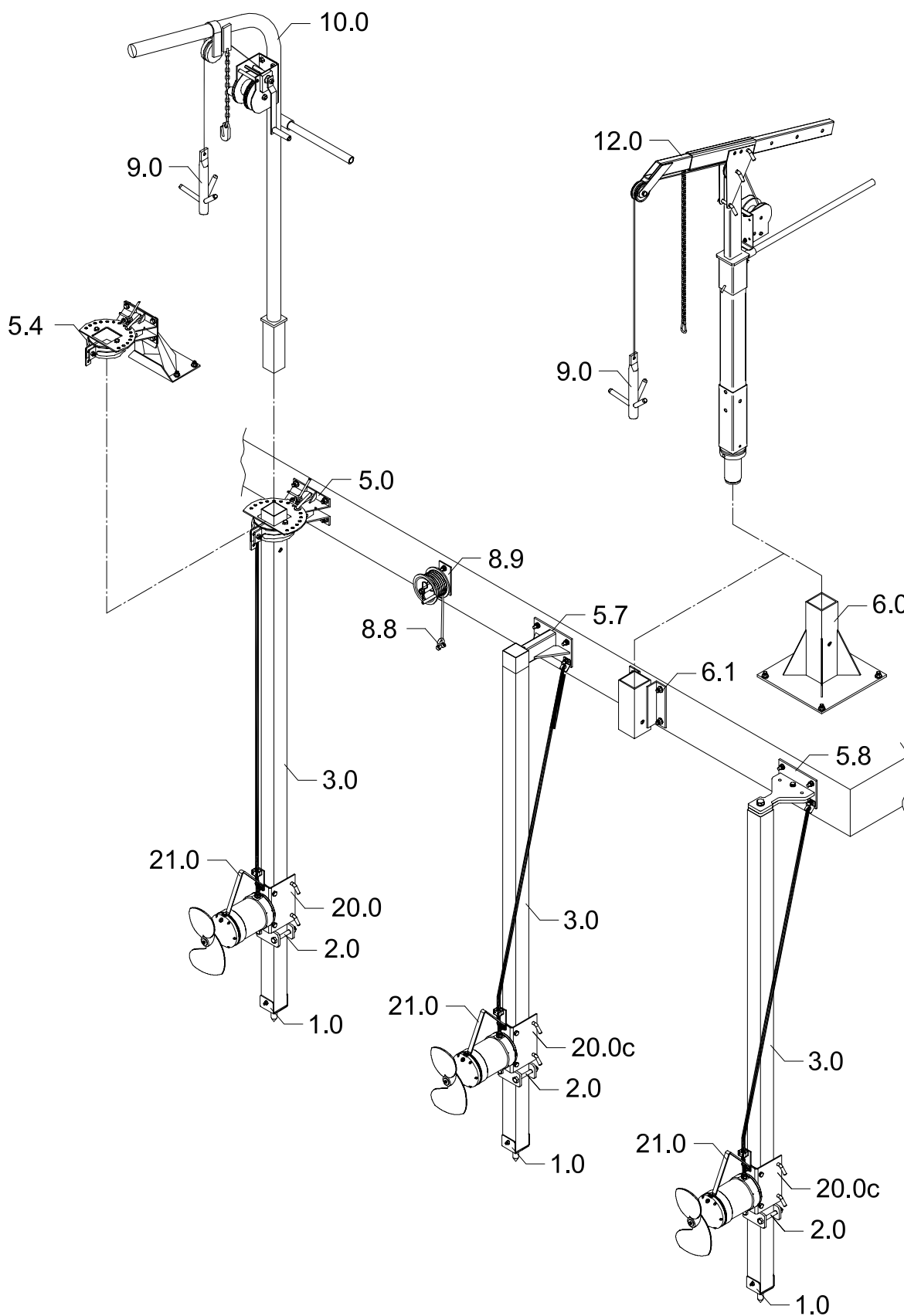

The right to make alterations is reserved